

Loss Prevention Systems



Lockboxes



LOSS PREVENTION SOLUTIONS 2023

marketingIMPACT LIMITED



Gondola Showcases



Swipecard™



Other Theft Deterrents

Introduction

Since 1986, Marketing Impact has been helping retailers and manufacturers maximize product sales and simplify inventory management on shelves and sales floors in North America. From cutting-edge custom displays to traditional merchandising products and accessories, we are your source for effective display and merchandising!

Our current focus is to improve operation efficiency and reduce the impact of shrinkage on our customers. Regarding shrinkage, industry experts like NRF (National Retail Federation) estimate that "...retail shrink is an almost \$100 billion problem¹." This Loss Prevention Catalogue showcases the wide range of solutions we offer to the industry that can be tailored to fit your retail needs. If you can't find exactly what you're looking for in this catalogue, please call us or visit our website -- www.displaypeople.com! Our knowledgeable staff will work with you to create the ideal loss prevention solution.

OVER 36 YEARS OF EXPERIENCE SERVICING OUR VALUED CLIENTS



TABLE OF CONTENTS

Loss Prevention Systems	
NEW Sliding Multi-Door Security System	4
Flip-Door Security System	6
NEW Time-Delay Security System	8
Lockboxes	
Slide & Hide Lockbox	10
Sliding Doors Lockbox	12
Gondola Showcases	
Gondola Locking Showcase	14
Loss Prevention for Peg Hook Merchandisers	
Swipeguard™	16
Sweepguard	18
Protective Case for Peg Hook Merchandisers	20
Other Theft Deterrents	
Pushers and Dividers	22



¹ National Retail Federation (Sep. 14, 2022). *National Retail Security Survey 2022*. Retrieved on August 20, 2023, from <https://nrf.com/research/national-retail-security-survey-2022>

Sliding Multi-Door Security System

The **Sliding Multi-Door Security System** is designed to provide a barrier for high-value and high-theft products, while allowing customers to have ease of access to the products without help from a store associate. Made of PETG for durability and product visibility.

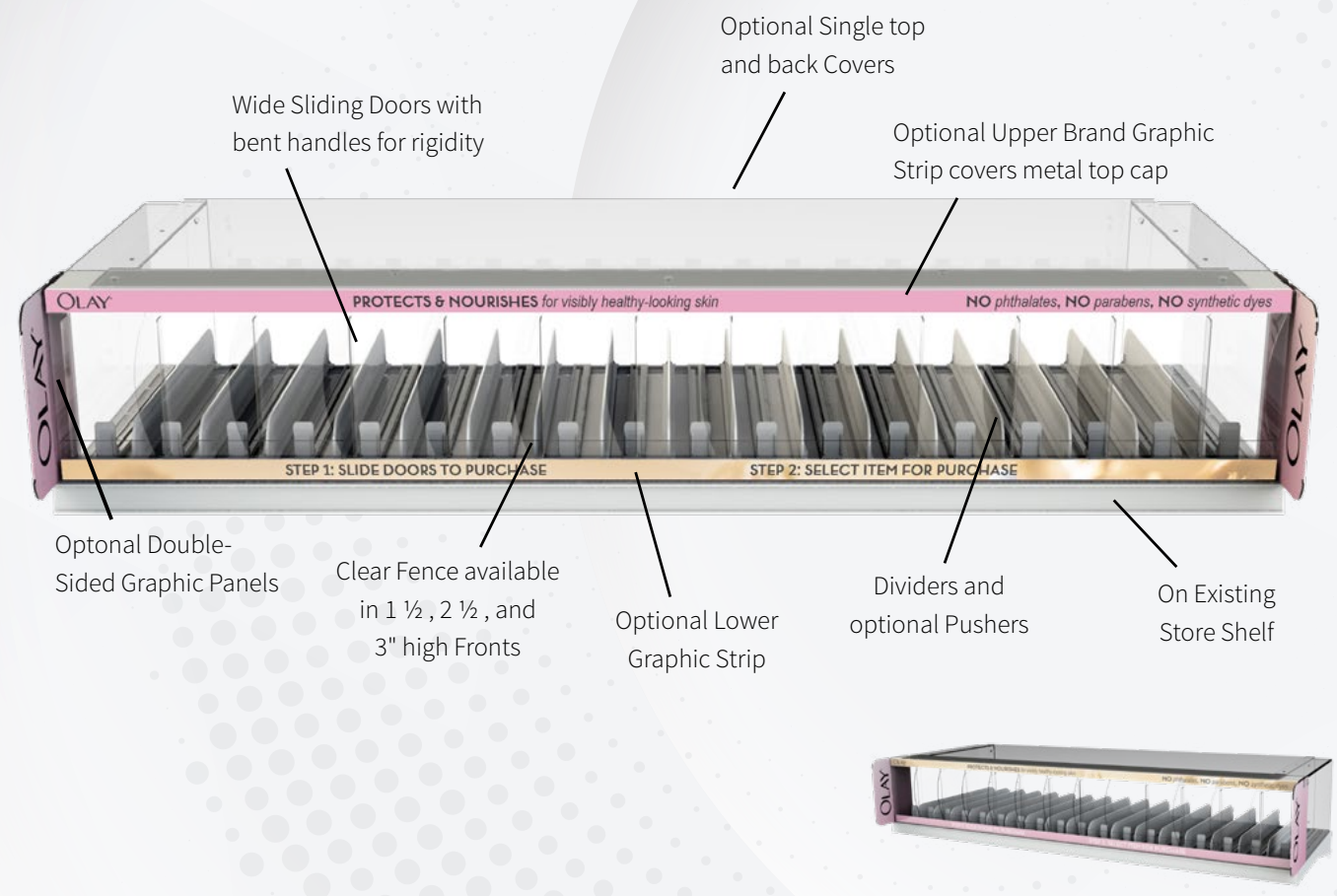

How it works



Slide Doors

Slide each individual door to access a product. One opening is present at all times allowing each individual door to freely slide from either side.



Grab Product

Product can be easily accessed once an opening is created from the sliding doors.

Retail Examples



Shelf-Mounted Tall Sliding Multi-Door for Wine

Key Advantages

- Ensure that high-value products can be displayed clearly while decreasing the threat of theft or damage to the product.
- Units can be designed to fit any size of product.
- Deters theft or damage of products by requiring customers to access products one at a time by moving the sliding doors.
- Mounts to existing shelves or to the upright.
- Available in any length, height or depth.
- Optional pushers and dividers.
- Option to ship fully assembled to be mounted on a shelf, or ship flat in parts to be assembled between existing shelves.

Flip-Door Security System

The **Flip-Door Security System** is designed to provide a barrier for high-value and high-theft products, while allowing customers to have ease of access to the products without help from a store associate. Made of PETG for durability and product visibility.



Key Advantages

- Ensure that high-value products can be displayed clearly while decreasing the threat of theft or damage to the product.
- Units can be designed to fit any size of product.
- Deters theft or damage of products by alerting associates with an alarm system that activates upon flipping up the door.
- Alarm is optional and completely customizable.
- Bottom fence and flip-door can be made to any length or height.
- Easy to install on any existing shelf.
- Options with pushers and dividers available.

How it works



Display Product Clearly

Product is clearly visible behind Flip-Door and easily accessible to customers.



Lift Flip-Door to Remove Product

Product can be easily accessed once Flip-Door is lifted and alarm will sound alerting nearby associates. Two sound settings are available for the alarm to alternate between each door lift.

Retail Examples



Flip Door with Alarm for Baby Formula at Rexall



Flip Door with Alarm for Razors

Time-Delay Security System

The **Time-Delay Security System** is designed to provide a barrier for high-value and high-theft products, while allowing customers to have ease of access to the products without help from a store associate. Customers may lift an individual handle to access the associated product, causing all other products in the system to remain locked in place. In order to access another product, the customer is required to wait 30s for the other handles to become available. Made of metal and PETG for durability and product visibility.

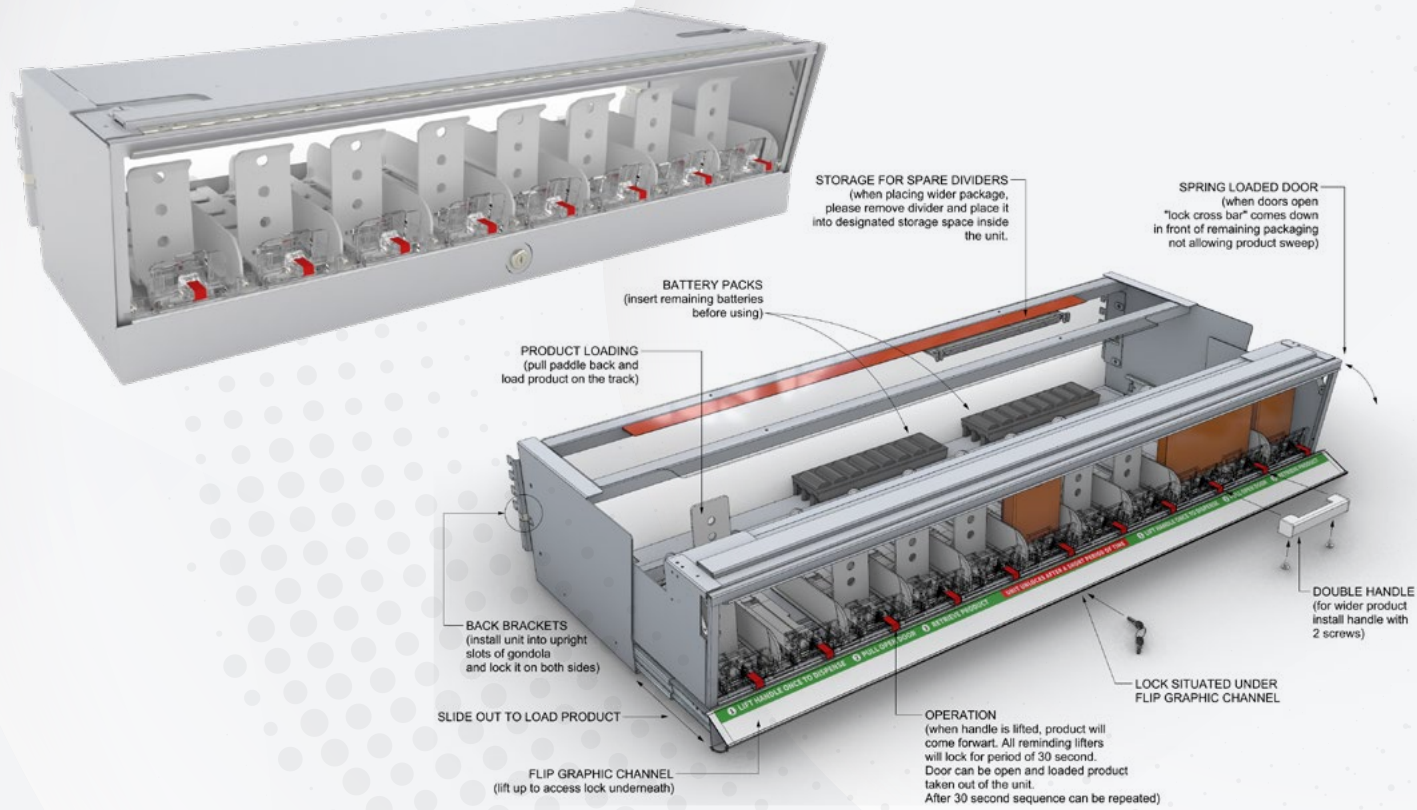

How it works



Push Handle Up

Push the handle up to unlock the door for the associated product. Once a handle is pushed up, all other handles remain locked for 30 seconds to protect other products and prevent shelf sweeping.



Grab Product

Product can be easily accessed once a handle is pushed up.

Retail Examples



Time-Delay Security System for Razors at Sobeys's



3-Tier Time-Delay Security System for Razors

Key Advantages

- Ensure that high-value products can be displayed clearly while decreasing the threat of theft or damage to the product.
- Units can be designed to fit any size of product.
- Deters theft or damage of products by requiring customers to access products one at a time via each door handle.
- Mounts to existing shelves or to the upright.
- Available in 36" or 48".
- Optional pushers and dividers.
- Ships fully assembled for easy installation.

Slide & Hide Lockbox

The **Slide & Hide Lockbox** is designed to secure high-value and high-theft products, allowing customers to purchase only with the assistance of a store associate. The Slide & Hide feature allows the Lockbox door to remain open while stocking. Made of PETG for durability and product visibility.



US Patent Number 11 147 394

Key Advantages

- Ensure that high-value products can be displayed clearly while removing the threat of any theft or damage to the product. The Slide & Hide feature can quickly transform the Lockbox into an open and accessible display.
- Units can be designed to fit any size of product.
- Keeps product safe from theft or damage while showcasing the product clearly.
- Open and slide the door under the top of the Lockbox to switch the Lockbox into an open display cabinet.
- Mounts to existing shelves or to the upright.
- Available in any length, height or depth.
- Available in Single or Double Lock Mechanism.
- Optional pushers and dividers.
- Ships fully assembled or unassembled.

Key Features

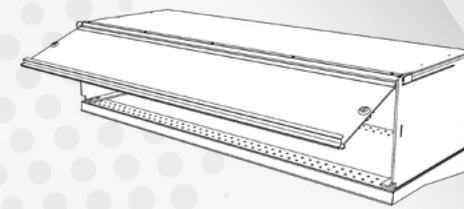

Garage-Door Functionality

Easily switch between keeping a secure merchandiser that is only accessible to staff and having an open display for customer convenience or easy restocking.

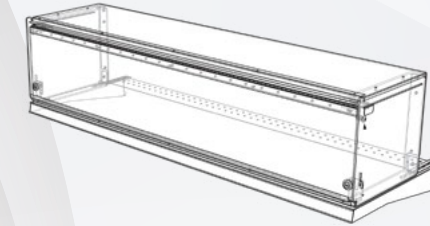

Double Lock System

The Double Lock System ensures that there are no weak points once the front door is locked into position while maintaining a clear view into the display. Option for single lock is also available.

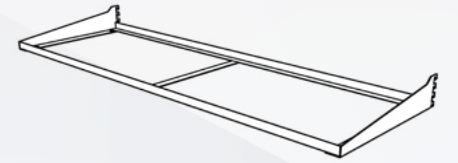

Flexible Mounting Options

The Slide & Hide Lockbox can easily be mounted without the need for shelves and with added support using a custom metal frame that mounts to the upright. Option to mount to shelf is also available.

Retail Examples



Slide & Hide Lockbox for Baby Formula



Slide & Hide Lockbox for Baby Formula

Sliding Doors Lockbox

The **Sliding Doors Lockbox** is designed to secure high-value and high-theft products, allowing customers to purchase only with the assistance of a store associate. Made of PETG for durability and product visibility.

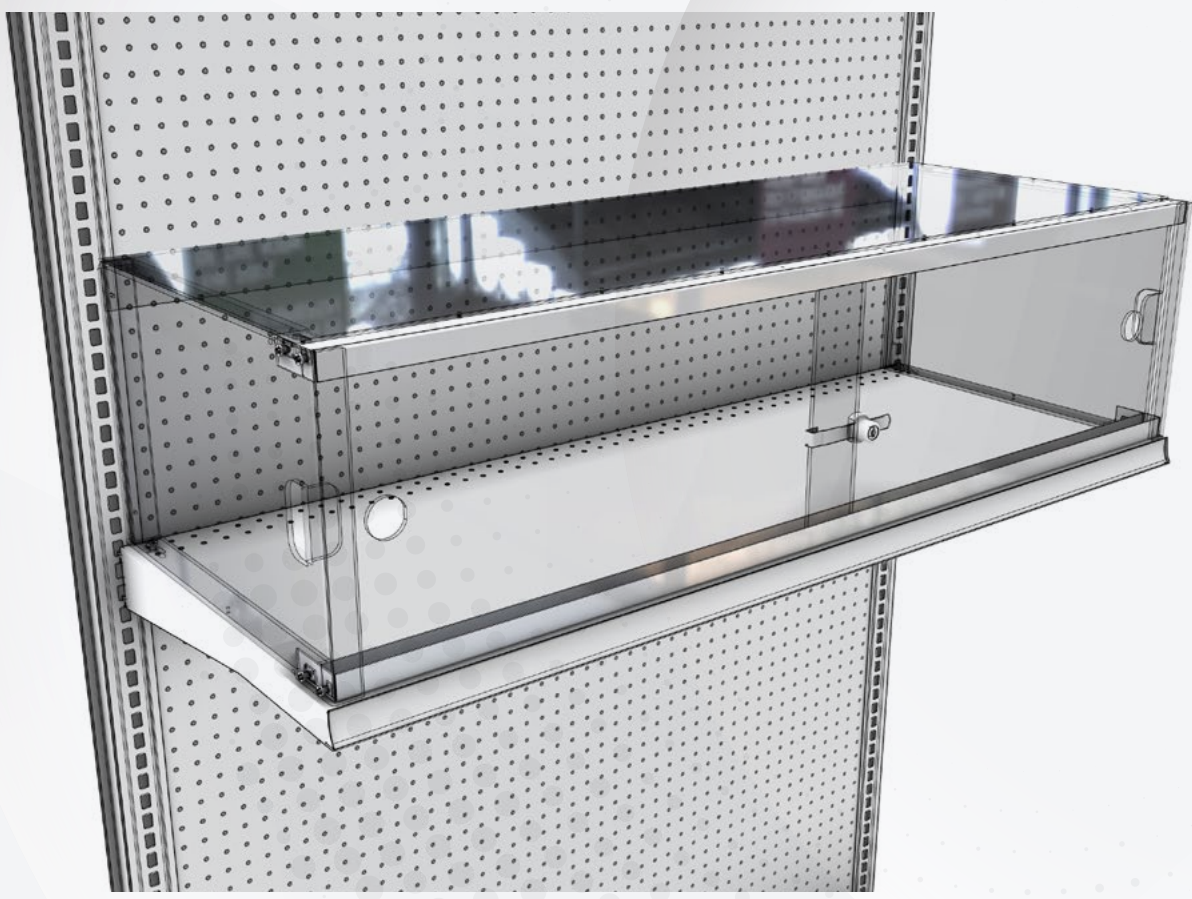

Key Advantages

- Ensure that high-value products can be displayed clearly while removing the threat of any theft or damage to the product.
- Units can be designed to fit any size of product.
- Keeps product safe from theft or damage while showcasing the product clearly.
- Mounts to existing shelves or to the upright.
- Available in any length, height or depth.
- Optional pushers and dividers.
- Ships fully assembled or unassembled with option to ship flat to be assembled in store.

Key Features

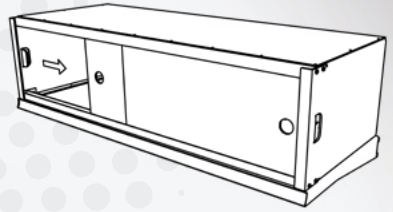

Sliding Doors Functionality

Product always stays behind doors in this traditional sliding doors system. Unlock and slide open a single door to access product without exposing merchandise behind the other door.

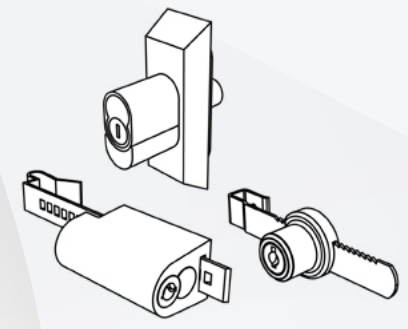

Single Lock System

The Single Lock System ensures both sliding doors can be inaccessible. Customization available for lock with option of ratchet lock.

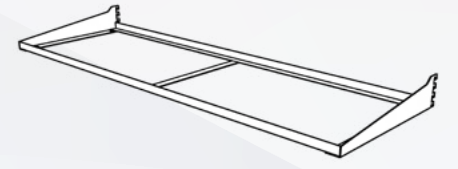

Flexible Mounting Options

The Sliding Doors Lockbox can easily be mounted without the need for shelves and with added support using a custom metal frame that mounts to the upright. Option to mount to shelf is also available.

Retail Examples

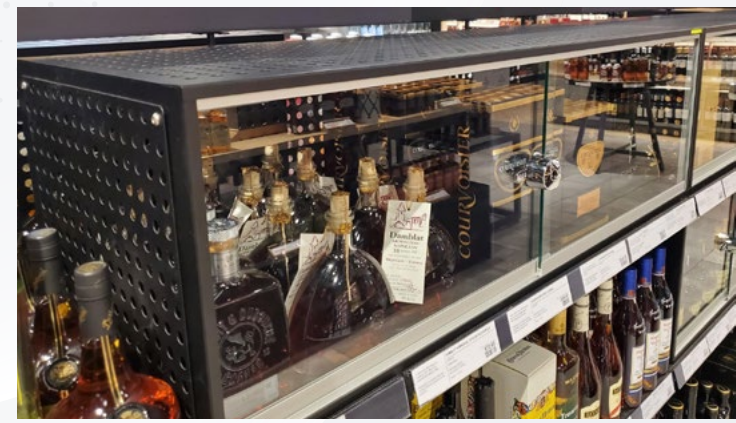

Shelf-Mounted Sliding Doors Lockbox for Brandy at LCBO



Sliding Doors Lockbox for Wine at LCBO

Gondola Locking Showcase

Transform most gondola systems (separate system) with our **Gondola Locking Showcase**. Protect sections of the gondola containing valuable product with easy-to-install tempered glass and locks. A clear product top shelf display in addition to sliding glass doors that are secured with a staff-accessible lock prevents theft while maintaining a neat display.

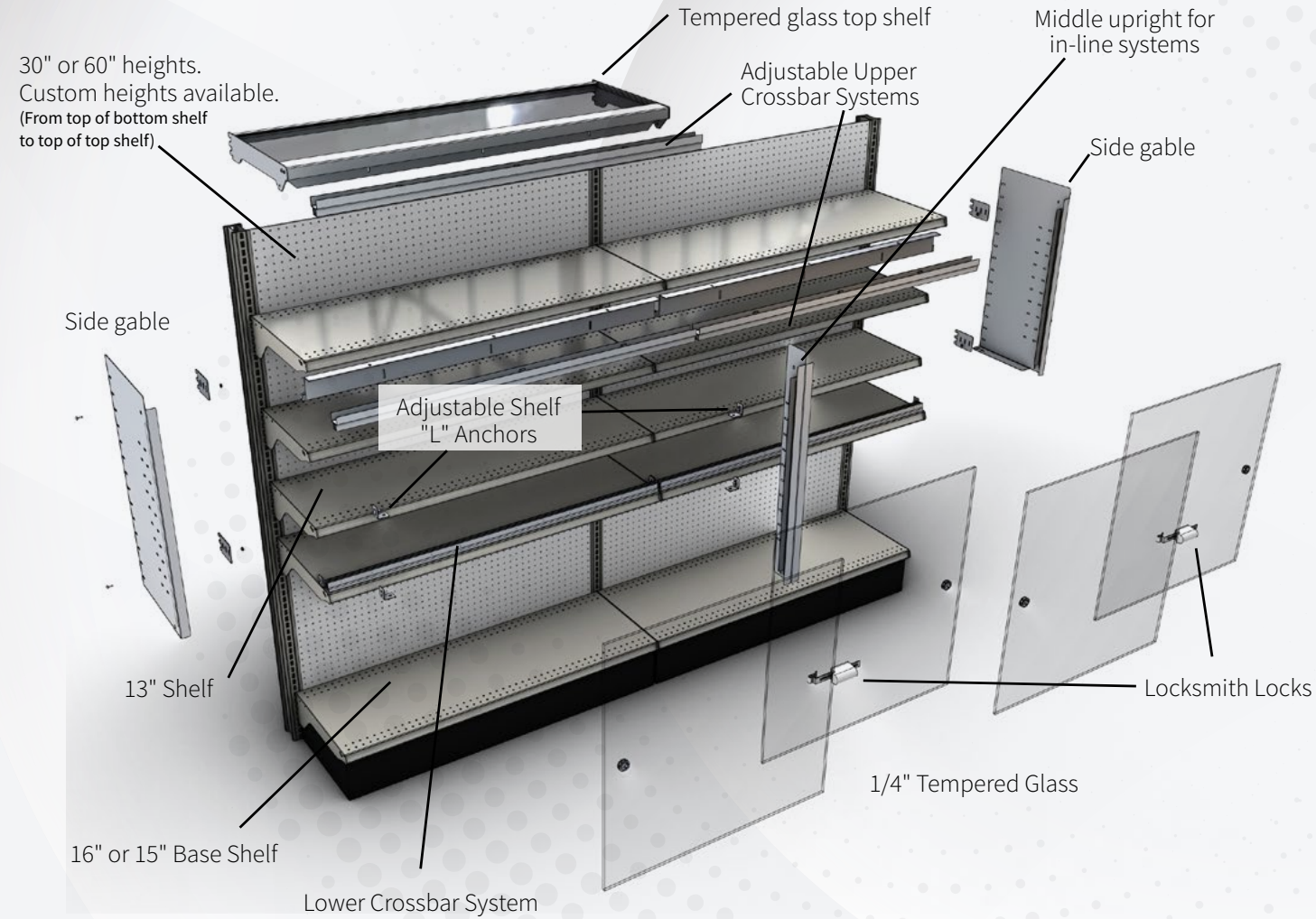

How it works

The Gondola Locking Showcases allow you to extend your secured showcase to as many units as needed, enabling your retail environment to safely display a wide variety of valuable merchandise at quantity.



Single Modular System



In-Line Modular System



30" In-Line Modular System
with glass top



60" In-Line Modular System
with glass top

Key Advantages

- Clearly display valuable merchandise in your retail environment, secured behind tempered sliding glass doors.
- Provide direct access exclusive to your staff with a Locksmith key system. The crossbar system also prevents glass doors from being lifted to prevent theft.
- The modular system allows for ease of scaling units horizontally with the in-line setup. Various heights are available to meet your shelving needs and easily interfaces with gondola systems (separate system).
- Easy-to-install glass doors, pre-assembled crossbar system and shelving brackets for precise adjustable heights.

Swipeguard™ Peg Hook System

Swipeguard™ prevents product sweeping from peg hooks by allowing customers to only take one product at a time. It quickly installs on existing pegboard hooks up to ¼” diameter without needing to remove products from the hook.



Key Components

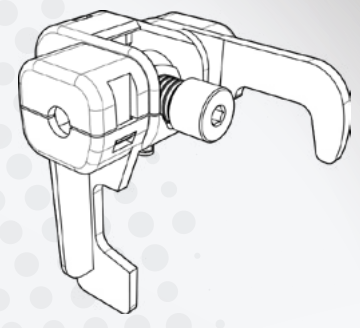

Swipeguard™
The Swipeguard™ prevents product sweeping from peg hooks by allowing customers to take one product at a time. It installs quickly on existing pegboard hooks up to ¼” diameter with no need to remove the products that are already on the hook.

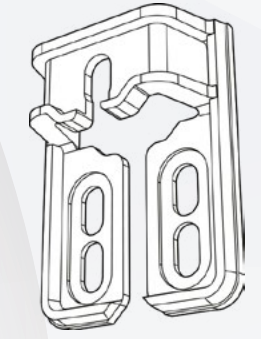

Swipeguard™ Backplate
The Swipeguard™ Backplate prevents theft of products on peg hooks by securing the hook to the pegboard with two push pins. The simple installation means this backplate is an easy upgrade to your theft prevention strategy.

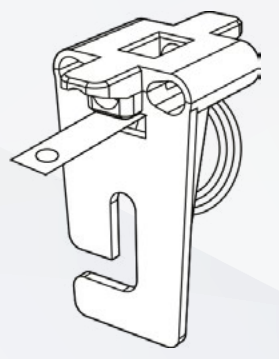

Swipeguard™ Pusher
The Swipeguard™ Pusher turns a peg hook into a Swipeguard™ Hook Pusher! Use the Swipeguard™ Pusher to keep products front-faced. The no-tool installation makes this a great enhancement to your secure pegboard merchandising.

Key Advantages

- Ensure your retail space is protected from theft while maintaining a front faced and organized retail experience on your existing peg hook displays.
- Modular components allow for installation on metal peg hooks of various sizes and retrofitting on existing pegs hooks.
- Products remain easily accessible while preventing product theft.
- Swipeguard™ can be easily installed onto peg hooks without having to remove the product, allowing for quick installation.

Retail Examples



Swipeguard™ for Razors at Walmart



Swipeguard™ for Razors

Sweepguard Peg Hook System

Sweepguard prevents product sweeping from peg hooks by deterring multiple products from bypassing the front clip. It quickly installs on existing pegboard hooks up to 1/4" diameter without needing to remove products from the hook.



Key Advantages

- Ensure your retail space is protected from theft while maintaining a front faced and organized retail experience on your existing peg hook displays.
- Modular components allow for installation on metal peg hooks of various sizes and retrofitting on existing pegs hooks.
- Products remain easily accessible while preventing product theft.
- Sweepguard can be easily installed onto peg hooks without having to remove the product, allowing for quick installation.

Key Components



Sweepguard Product Stopper

The product stopper ensures product on peg hooks can not be easily removed all at once. It can be easily placed onto existing peghooks.

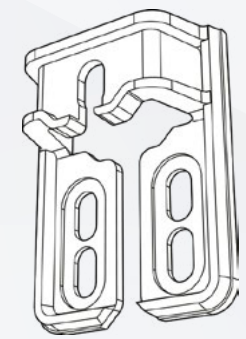

Optional Backplate

The optional backplate prevents theft of products on peg hooks by securing the hook to the pegboard with two push pins. The simple installation means this backplate is an easy upgrade to your theft prevention strategy.

Retail Examples



Sweepguard for Command Hardware

Protective Case for Peg Hook Merchandisers

A **Protective Case** prevents product sweeping from peg hook merchandisers by shielding products that are behind the frontmost product. Customers are only able to access products within the case by taking one product at a time. The Protective Case is compatible with all types of peg hook merchandisers, such as the Spiral Anti-Sweep Hook, Sweepguard, and Swipeguard™. The Protective Case quickly installs on existing pegboard hooks up to 1/4" diameter without needing to remove products from the hook.



Key Advantages

- Ensure your retail space is protected from theft while maintaining a front faced and organized retail experience on your existing peg hook displays.
- Modular components allow for installation on metal peg hooks of various sizes and retrofitting on existing pegs hooks.
- Products remain easily accessible while preventing product theft.
- Protective Cases can be easily installed onto peg hooks without having to remove the product, allowing for quick installation.

Key Feature

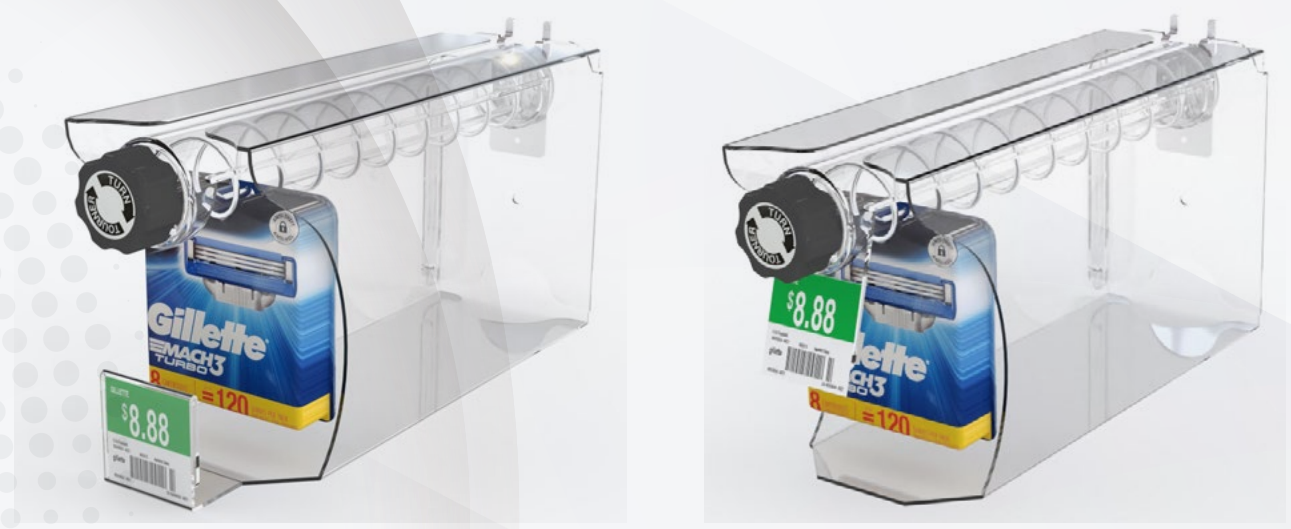

Alternate Placement of Price Tickets

The Protective case for Peg Hook Merchandisers is completely customizable allowing for different placements of price tickets to suit your retail needs.

Retail Examples



Protective Case with Swipeguard™



Protective Case with Spiral Anti-Sweep Hooks

Pushers and Dividers

Pushers and Dividers reconfigure your shelf space into a self-managing and efficient display.



Key Components

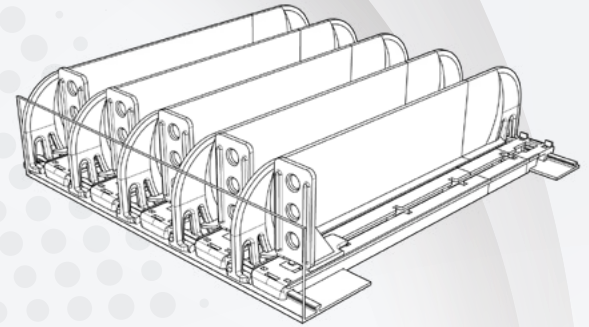

Shelf Kit (Example Set Up)

In this example, clear Shelf Dividers, T-Snap tracking and the front fence are key components required to outfit your shelf with the Gen3 Light Duty Pusher System.

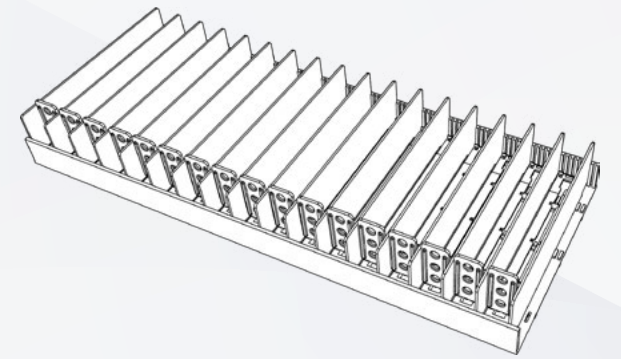

Tray & Dividers (Example Setup)

In this example the clear tray and divider system allows for easy product merchandising with a Gen3 Pusher System. The dividers can easily be placed in slots in the tray to accommodate your product width.

Key Advantages

- Simple to organize and manage products while maintaining a front-faced section in your retail environment.
- Prevents mass and quick clearing of shelves and discourages theft.
- Product remains front-faced and neatly organized and used as a point-of-purchase value addition.
- Price tickets are placed neatly in the holder at the front of the display without additional ticket holders.
- Stocked in white and black.
- Custom sizes and colors available.

Retail Examples



Pushers and Dividers for Glue



Dividers with Front Graphics for Cereal

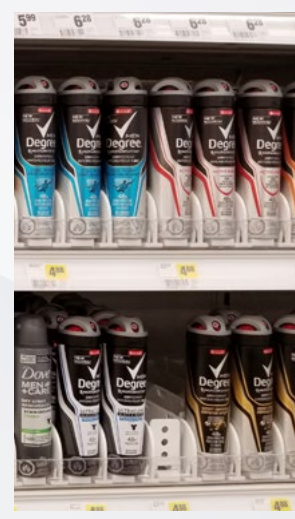

Pushers and Dividers for Deodorant at Loblaws

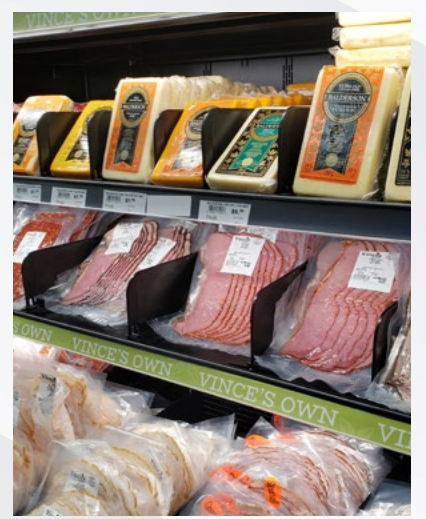

Dividers for Deli and Cheese



50 Planchet Road
Concord, Ontario, Canada
L4K 2C7

Telephone
(905) 738-0888

Fax
(905) 738-1334

sales@displaypeople.com
www.displaypeople.com